

Mechanical Details

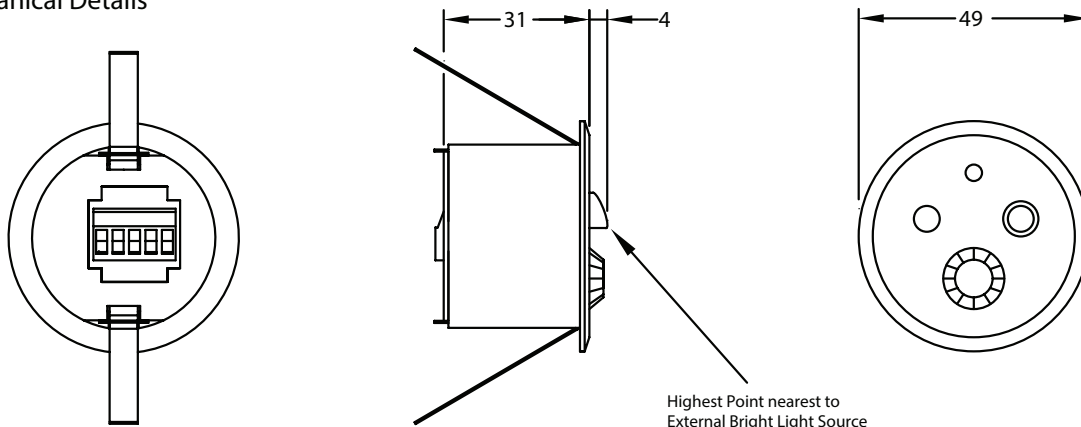

Mechanical Fixing

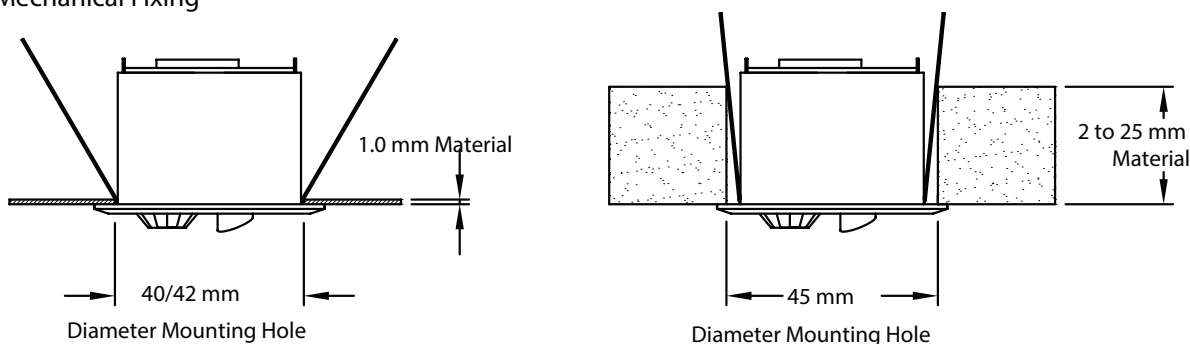

iCAN Network Connections

The CAN Sensor uses iCANnet connections to ensure reliable and responsive transfer of control signals between multiple devices. Cable connections are made to a removable 5-way connector block located at the rear of the Sensor housing.

Note: To aid the use of the recommended iCANnet cable, the use of suitable double wire end ferrules is recommended.

Function	iCANnet Cable Colours
0V	Black
CAN L	Blue
Shield	Silver
CAN H	White
+VDC	Red

Maximum segment distance: 500m (1640 ft)
Devices per segment: 100 (without bridge or repeater)
Consult iLight for information on alternative cable types.

Network Power Requirements

Nominal operating voltage: 15V (12-18V)
Nominal operating current: 13mA

IMPORTANT NOTE: Connecting a mains potential cable to the iCAN Network terminals is likely to damage the unit and other devices connected, and invalidate warranty.

iCANnet Termination

The iCANnet link is a 'daisy chain' protocol that requires termination on the devices located at either end of the iCANnet chain.

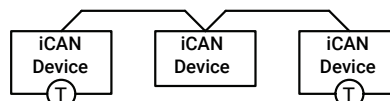
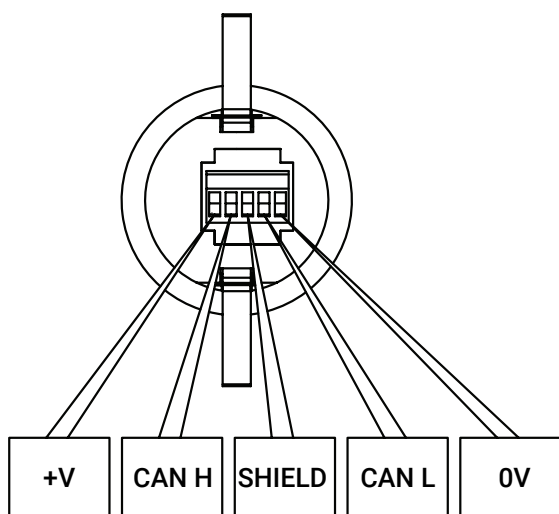

Ⓣ - Indicates where a termination is required.