

# TSC30 - Colour Touchscreen

## Installation guide

### Introduction

The LCD touch screen is a flexible device that provides an intuitive “user friendly” method of interfacing to the lighting control system. The Colour Touchscreen provides virtually a limitless flexibility of system configuration and control. This method of control is ideal for areas where complex and flexible control is required. It is completely software based, and programs can be tailored to suit the precise needs of the user. It also offers many advantages over conventional control panels not least of which are multiple control functions.

### Supplied Parts

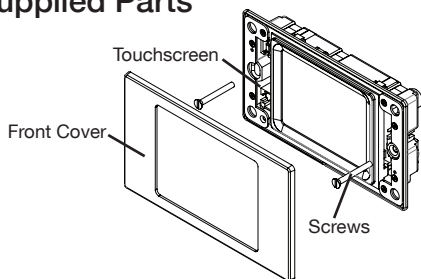

### Dimensions

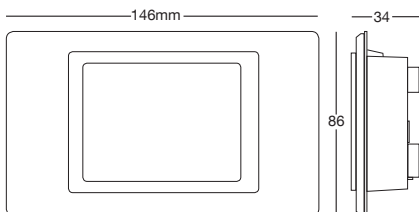

### Fixing to a wallbox

The touchscreen fits into a standard 35mm deep UK double gang backbox (not supplied)

To avoid damage to the display, it is recommended that the touchscreen is installed after painting/wallpapering has been done.

### Care and Maintenance

The front cover plate should only be cleaned gently with a clean, ‘dry to damp’ cloth. Abrasive cleaners, polishes, solvent based cleaning agents, or alkali based cleaners should not be used.

### Connecting the touchscreen

#### Power Connection

A separate power supply is provided with the unit (+9V DC 1A). Connect the power supply to the 2-pin power connector.

#### Network Connection

iCAN Network cable connections are made to the removable 5-way connector block also located at the rear of the TSC30 main body.

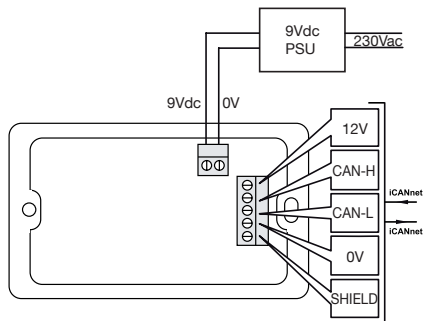

Function	Network Cable Colours
+12Vdc	Red
CAN H	Blue
CAN L	White
0V	Black
Shield	Silver

It is not recommended to mix cable types in a single installation.

#### Network Cable

Maximum cable length: 300m (1000 ft.)  
 Max devices per segment: 100 (without bridge or repeater)

## Termination

The iCAN network link is a 'daisy chain' protocol that requires termination on the device located at either end of the chain.

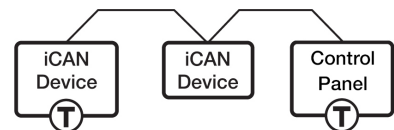

T - Indicates where a termination is required.

The TSC30 is supplied with a termination resistor fitted to the blue network connector. Remove this connector unless the touchscreen is at the beginning or end of the network.

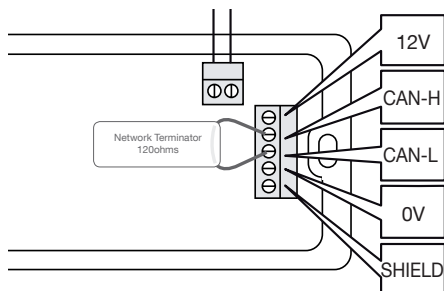

## Programming the TSC30 Colour Touchscreen

Using iLight programming software (available separately), you can program the pages in the touchscreen. Downloading the configuration is done via the USB connector. DO NOT connect the touchscreen to a PC until after programming software has been installed.

Note: The sockets are concealed behind the metal coverplate. This can be removed easily by unclipping from one side.

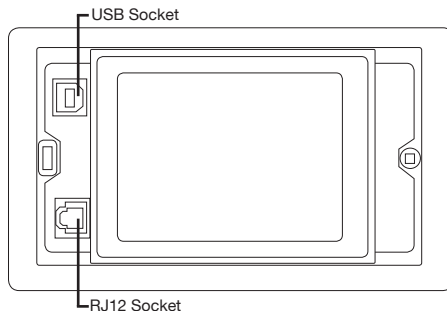

## Programming Other Devices

Access to the complete network is available from the front of the touchscreen. This allows easy access to programming all devices on the network. To program devices on the network, connect a PC Node to the RJ12 socket (PC Node available separately).

All products manufactured by Cooper Controls Ltd and identified with the iLight product series mark are warranted to be free from defects in material and workmanship and shall conform to and perform in accordance with Seller's written specifications.

For detailed warranty information, visit our website at [www.coopercontrol.com](http://www.coopercontrol.com)

This warranty will be limited to the repair or replacement, at Seller's discretion, of any such goods found to be defective, upon their authorized return to Seller. This limited warranty does not apply if the goods have been damaged by accident, abuse, misuse, modification or misapplication, by damage during shipment or by improper service.

There are no warranties, which extend beyond the hereinabove-limited warranty, INCLUDING, BUT NOT LIMITED TO, THE IMPLIED WARRANTY OF MERCHANTABILITY AND THE IMPLIED WARRANTY OF FITNESS.

No employee, agent, dealer, or other person is authorised to give any warranties on behalf of the Seller or to assume for the Seller any other liability in connection with any of its goods except in writing and signed by the Seller. The Seller makes no representation that the goods comply with any present or future federal, state or local regulation or ordinance. Compliance is the Buyer's responsibility.

The use of the Seller's goods should be in accordance with the provision of the National Electrical Code, UL and/or other industry or military standards that are pertinent to the particular end use. Installation or use not in accordance with these codes and standards could be hazardous.