



Ineo

Ineo Control Panel Range

Key Features

- Available in Black, White & Ivory finishes
- Standard or custom engraving on buttons
- Configuration stored in Non Volatile EEPROM
- Firmware storage in reflashable FLASH memory over iCAN network
- Configurable start up mode
- CE compliant to all relevant standards
- Designed and manufactured to ISO9001:2015 standards

Overview

Ineo is a versatile range of specification grade control panels that set new standards in intuitive layout and operation. Users are quickly drawn to the large on/off button controls with associated up/down adjustments. Panels may be ordered with engraved buttons and with a choice of 10 panel configurations. There is even a choice of button size and colour.

Ineo control panels can be ganged together to meet specific project needs. Individual buttons have backlight indicator lights and strong tactile feedback.

Ineo is the clean, elegant, and simple way to control lighting on your project.



2 Small buttons



4 Small buttons



6 Small buttons



1 Large button



2 Large buttons



3 Large buttons



1 Large button
Raise & Lower
On / Off



2 Small buttons
On / Off
Raise & Lower



2 Large button
Raise & Lower
On / Off



4 Small buttons
On / Off
Raise & Lower



Powering Business Worldwide

Button Functions

- Scene selection
- Scene raise/lower
- Channel raise/lower
- Toggle on/off
- Toggle raise/lower
- True off
- Open/close (for curtains or blinds)
- Raise/lower (for motorized screens)
- Task (start/stop a sequence)

Infra Red Receiver - When fitted takes place of bottom button

Mechanical Data

Buttons include scene, raise, lower, on, off functionality.

Choice of large or small button caps

Standard or custom engraving on buttons

Tap on/off feature to override fade time

All plastic construction with a separate snap-on surround

Requires NEMA (US Style) backbox 3" h x 2" w x 2.5" d

Electrical Data

10 panel variants selectable via Source Controller

Each button individually configurable via iCANsoft

Variable fade times programmable from 0.1 seconds to 60 minutes per button

Built-in infrared receiver with learnable remote codes.

12Vdc powered direct from iCANnet™ network

Tested to withstand 12kV electro-static discharge without damage or memory loss.

Flash memory for future proof upgradeability

Environmental Data

Temperature Range: 0°C to +40°C

Humidity: 0% - 95% non condensing

Dimensions

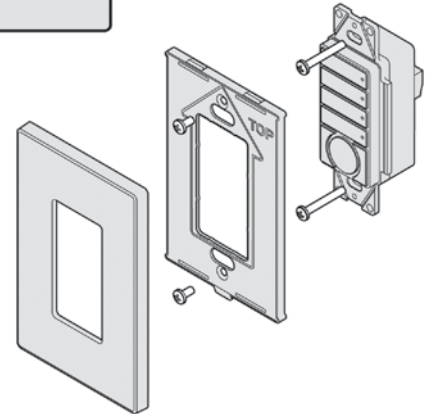
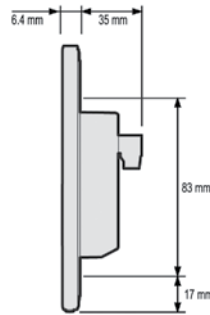
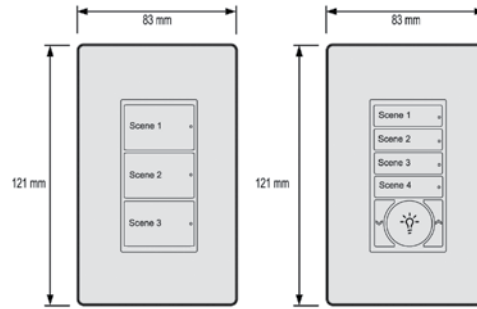

Ordering Codes

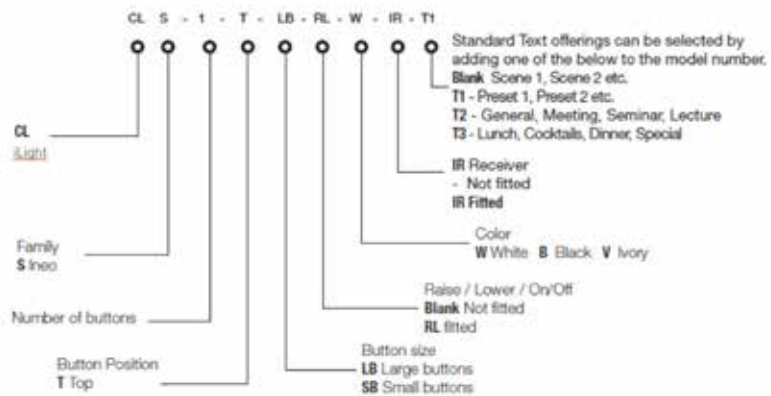

Typical Schematic

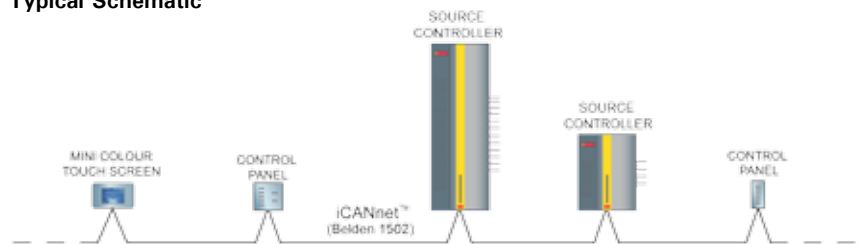

Contact your local Eaton office

T: +44 (0)1923 495495 F: +44 (0)1923 228796

E: enquiries@iLight.co.uk www.iLight.co.uk

Eaton Lighting Systems
20 Greenhill Crescent,
Watford Business Park,
Watford, Herts, WD18 8JA. UK
eatonlightingsystems.com

© 2018 Eaton
All Rights Reserved

Document No: INEO Rev10 0318

Changes to the products, to the information contained in this document, and to prices are reserved; so are errors and omissions.

Eaton is a registered trademark.

All other trademarks are property of their respective owners.



Powering Business Worldwide

