

Mechanical Data

Weight: 3.8 kg

Material: Sheet steel

Surface Treatment: RAL9016 powdercoat

Door: Lockable steel hinged door

Mains Cable Access

6 x 25.5mm/M25 knockout &

1 x 38.3mm/PGx knockout

Control Cable Access

1 x 25.5mm/M25 knockout

Terminal Sizes

Neutral: 2 x 25mm² & 13 x 16mm²

Earth: 2 x 25mm² & 13 x 16mm²

Climate Range

Temperature: +2°C to +50°C

Humidity: +5 to 95% non condensing

Ratings

Ingress Protection: IP20

Impact Resistance: IK07

In accordance with: IEC 62208:2011

Electrical Data

Supply: 230 volts +/- 10% 50/60 Hz

Protection: 6A MCB

Terminal Size:

Neutral: 2 x 25mm² & 13 x 16mm²

Earth: 2 x 25mm² & 13 x 16mm²

iCANnet™ screw terminals: 5 x 1mm²

Power screw terminals: 2 x 1mm²

RS485 screw terminals: 3 x 1mm²

Installation: Installation must be carried out by a suitably qualified electrician.

Control Data

Control: Via iLight network connection or Ethernet

Recommended Network Cable:

iCANnet™ Network Cable

Programming: Via Device Editor software.

TSEdesigner is required for the configuration of TSE Screens and associated App content and pages.

Installation Guide



EN1-TS11

TSEtouch Gateway Control Enclosure



Dimensions

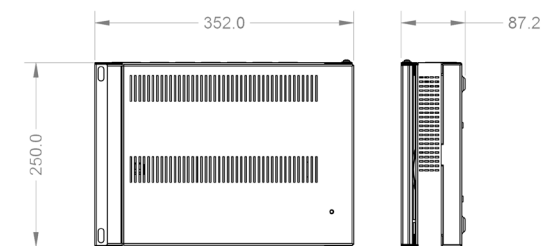

Overview

The TSI-1 Touchscreen Interface enables the use of multiple TSE55 and TSE80 colour touchscreens and ensures synchronization of screen configurations across an entire building installation. It also facilitates connection to iLight's TSEtouch app enabling personalised control from your compatible hand held smart device.

Additionally a built in scheduler allows for timed events to suit your building needs and BACnet capabilities for the integration of building services such as HVAC, further enhancing the capabilities of this powerful interface unit.

The compact design of EN1-TS11 delivers system flexibility as well as reducing installation costs and space used. Being part of the iLight system, it can be seamlessly integrated into flexible lighting schemes with any type of lighting load for commercial, architectural and residential applications.

The knockouts to the top of the enclosure have been designed to line up with any of the original iLight source controllers making replacement quick and easy in a retrofit environment.

A dedicated knockout is provided for iCANnet connection to the EN1-TS11 and several accessories are available to aid the installer in connection of the iCANnet™ network.

iLight

Usk House, Lakeside, Llantarnam Park,
Cwmbran, NP44 3HD, UK

t: +44 (0)1923 495495
e: enquiries@iLight.co.uk
www.iLight.co.uk

EU Authorised Representative

Cooper Lighting Netherlands B.V.
High Tech Campus
HTC 48
Eindhoven
5656 AE



E&OE. iLight reserve the right to make changes to the equipment without prior notice.
© iLight

Doc No: 9850-000884-00

Location

Control cabinets must be located in a dry, well ventilated location where the ambient temperature is within the range of +2°C to 50°C (humidity of +5 to +95% non-condensing).

The EN Series are designed to be mounted vertically on a suitable surface, capable of supporting the weight of the populated assembly. It is important to orientate the unit correctly to allow for effective airflow for ventilation.

It is recommended to leave 100mm distance between the control cabinet and walls or other equipment underneath and either side of the unit.

The EN series accommodate most common forms of cable management. Care should be taken not to obscure any ventilation grill on the enclosure.

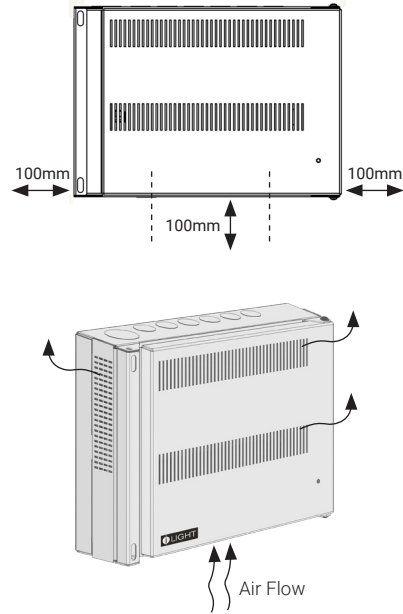

Mounting

Before mounting the cabinet to the wall, the cover will need to be removed. There are 4 screws behind the hinged door which, when unscrewed, allow the cover assembly to be removed.

In the rear section of each cabinet, there are 4 fixings holes, each accommodating up to 6mm diameter fixings. The top holes are 'key slot' design enabling the cabinets to first be hung and then secured onto place using the 2 lower fixings.

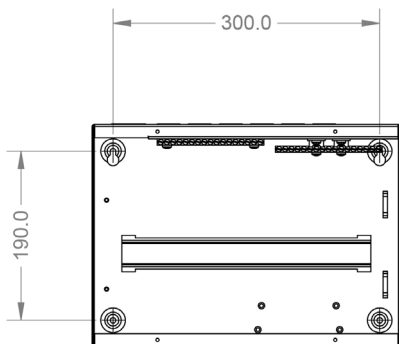

Supply and Control Wiring

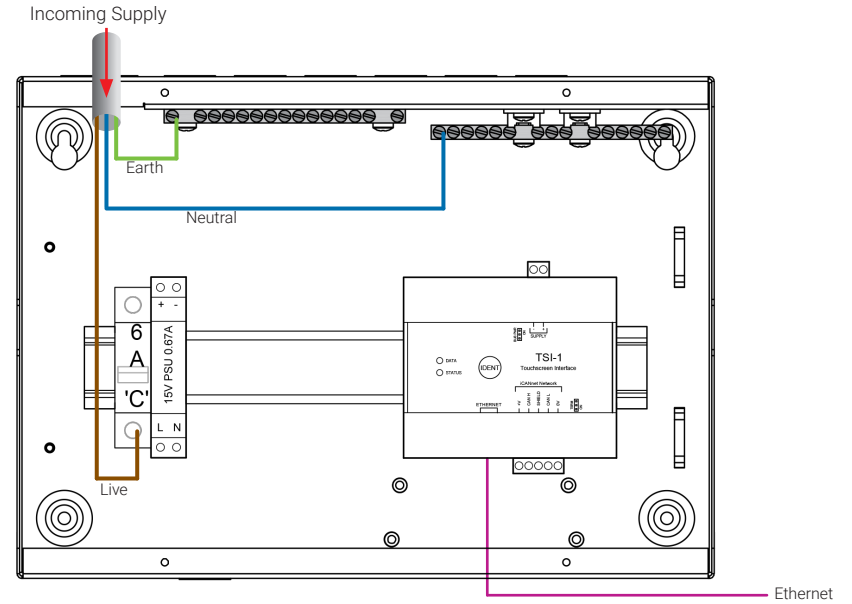

Accessories

ENACC-LND-INT - iCANnet Landing Card



ENACC-PRG-INT - iCANnet Programming Port and RJ12 lead



The optional landing card provides connection of the iCANnet Network to the internal panel network. M4 Threaded posts are provided as standard to support the installation of this optional card.

The card can then be connected to the optional RJ12 programming port via an RJ12 lead to provide external connection to the network for programming and maintenance.

