



MPD-W-EXT-12-24V

Weather proof microwave presence detector - wall mounted

Key Features

- For connection to iCAN networks via UIM, UIG-2, UIS or DALI-I-U devices.
- Microwave Sensor - Detects movement within the unit's detection range, allowing load control in response to changes in occupancy.
- Light Level Sensor - An integral adjustable photocell allows the lights to be kept off if there is sufficient ambient light.

Achievable Energy Savings

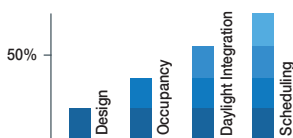

Code Compliance

- Improves BREEAM & LEED scoring for building sustainability.
- Contributes to energy reduction targets under Climate Change Levy (CCL) and Carbon Reduction Commitment (CRC).
- Qualifies for Enhanced Capital Allowance (ECA) applications.
- Delivers lighting control requirements under UK Building Regs - L2a & L2b and BRE: 498.



Overview

MPD-W-EXT-12-24V is an IP66 rated wall mounted low voltage powered microwave presence detector and is designed to provide automatic control of lighting, heating or ventilation loads when connected to the iCAN network*.

The MPD-W-EXT-12-24V detects movement using a highly sensitive microwave detector. This works by emitting low power microwave signals and measuring the reflections as the signals bounce off moving objects. The MPD-W-EXT-12-24V is optimised for wall mounting applications to give detection over long distances.

The internal light sensor provides additional energy saving in lighting applications. When an area is occupied lighting is only switched on when the level of natural light is below a preset level.

System timeout periods are adjusted in iCANsoft.

The MPD-W-EXT-12-24V may be powered from the iCAN network supply.



Powering Business Worldwide

Detection

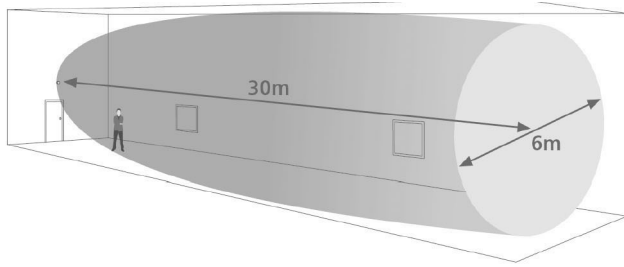

Area of high sensitivity  Area of lower sensitivity 

Ideal for larger areas where an IP rating is required.
Maximum recommended mounting height: 3m

Technical Specifications

Weight: 0.25kg

Supply Voltage: Min 11.5VDC max 36VDC, min 10VAC
max 26.5VAC

Power consumption: On 1.01W Off - 712mW (Additional power supply may be required depending on total network load)

Terminal Capacity: 2.5mm²

Timeout period: Adjustable 10 seconds to 99 minutes using IR programmer.

Light level & microwave sensitivity: Adjustable on the sensor using IR programmer.

Fixing method: Surface fixing by screws (not supplied) .

Temperature: -10°C to 35°C

Humidity: 5 to 95% non-condensing

Material: (casing) Polystyrene Type Class 2

IP rating: IP66

Compliance: EMC-2004/108/EC, LVD-2006/95/EC

Safety: The microwave radiation emitted by these units is extremely low power. At a distance of > 50mm the power density is <6% of the ANSI IEEE C95.1 –1991 recommended microwave power density. At a distance of 5mm from the unit it is <84% of recommended power density.

Remote Control Programmers (ordered separately)

HHIR-PROG: Hand held IR programmer for setting sensor timeout, daylight threshold and microwave sensitivity only.

HHIR-LCD-PROG: Advanced hand held IR programmer with LCD display for reading and setting sensor timeout, daylight threshold and microwave sensitivity only.

Dimensions

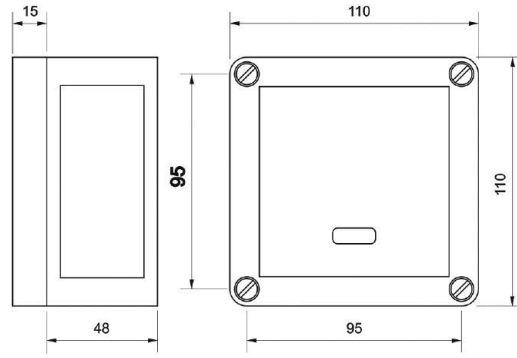

Commissioning

Microwave on/off time and threshold light level can be set via the hand held IR remote for commissioning.

*This sensor is intended for use with UIS, UIG-2, UIM and DALI-I-U devices on iCAN networks. Additional network commissioning will be required.

Order Codes and Frequency Compatibility

MPD-W-EXT-12-24V (Then add suffix as follows)

Code	Region	Frequency
blank	UK, China, India, Middle East, Malaysia, Hong Kong, Singapore	10.687GHz
-R2	Australia and all of Europe except: UK, France, Portugal, Germany, Switzerland, Austria, Slovak Republic, Republic of Ireland	10.525GHz
-R3	France, Portugal, Switzerland	9.900GHz
-R4	Germany, Austria, Slovak Republic	9.350GHz
-R5	Republic of Ireland	10.41GHz

Accessories

PSU15-DIN-C: 15V Power Supply

Contact your local Eaton office

20 Greenhill Crescent, Watford Business Park,
Watford, Herts, WD18 8JA. UK
T: +44 (0)1923 495496 F: +44 (0)1923 228796
E: enquiries@iLight.co.uk www.iLight.co.uk

Eaton Lighting Systems
20 Greenhill Crescent,
Watford Business Park,
Watford, Herts, WD18 8JA. UK
eatonlightingsystems.com

© 2017 Eaton
All Rights Reserved

MPD-W-EXT-12-24V Rev4 0117

Changes to the products, to the information contained in this document, and to prices are reserved; so are errors and omissions.

Eaton is a registered trademark.

All other trademarks are property of their respective owners.

EATON

Powering Business Worldwide

CE

